

PERFORMANCE DATA

PAVER (STAGE V)

BF 300 P-2



Greatest durability



Shorter set-up times



Exemplary efficiency

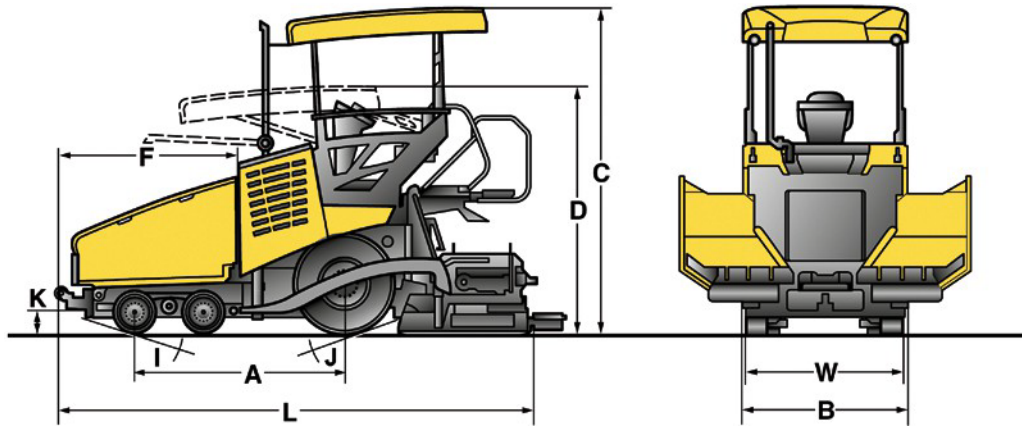

Dimensions in mm

| | A | B | C | D | F | I | J | K | L | W |
|---------------------------|----------|----------|----------|----------|----------|----------|----------|----------|----------|----------|
| BF 300 P-2 S 340-2 | 2265 | 1880 | 3500 | 2690 | 1917 | 22° | 16° | 268 | 5050 | 1700 |



Hydraulic front gate – for a clean material flow.



Impact-free docking – dampened bumper.



Save up to 17 % fuel – demand-driven hydraulics – with BOMAG ECOMODE.



Heats up nearly 60 % quicker – unique MAGMALIFE heating system.

Technical Data

BOMAG BF 300 P-2

Weight CECE

With S340-2 V screed / S340-2 TV screed kg 10300 / 10400

Dimensions

Transport length..... mm 5050
Transport width..... mm 1880
Transport height..... mm 2690
Inner turning radius..... mm 2900
Outer turning radius..... mm 4600

Travel characteristics

Travel speed km/h 0-15
Working speed..... m/min 0-30 variable

Drive

Engine manufacturer Kubota
Type V3307-CR-T-ESB
Emission stage EPA/CARB TIER 4 / EU STAGE V
Cooling liquid
Number of cylinders / Displacement cm³ 4 / 3331
Rated power..... kW / HP 54,6 / 72,8
Rotary Speed min⁻¹ 2250

Undercarriage

Rear tyres / Number..... 2
Type 13 R 22.5
Front tyres / Number 2
Diameter mm 470
Width..... mm 270

Hopper

Capacity..... m³ 4,8
Width (wings open)..... mm 3080
Width (wings closed)..... mm 1730
Length..... mm 1760
Filling height (middle)..... mm 515

Conveyor

Number..... 2
Rotary speed..... m/min⁻¹ 37
Individual control Standard
Reversing operation yes

Auger

Number mm 2
Auger diameter mm 280
Rotary speed..... m/min⁻¹ 87
Reversing operation Standard

Screed

S 340-2
Basic width retracted..... mm 1700
Basic width extended..... mm 3400
Min. width with reduction skids..... mm 700
Mat thickness..... mm 250
Screed plate depth..... mm 330
Screed plate thickness mm 12
Heating electric
Crown % -2,5 ... +4,5
Tmaper frequency Hz N.A. / 0-25 Hz
Vibration frequency Hz 0-60 / 0-60 Hz
Basic weight..... kg 1600 / 1800
Max. working width..... mm 4400

Filling capacities

Fuel l 93
Hydraulic oil l 74

Standard Equipment

Operator compartment

- SIDEVIEW
- Driver's seat: with swivel and side-shift
- Dashboard protection
- Hydraulic hinged roof
- Digital display for machine Management

Tractor

- ECOMODE
- Separate control of hopper wings
- Hydraulic, height adjustable auger
- 2 proportionally controlled and reversible wear-resistant cast augers; screw blades separately replaceable
- 2 independent and reversible scraper belts; high-wear resistant plates
- 2 x 6 wheel drive
- LED roof working lights

Screed

- L.C.S. Screed relief and traction increase system
- Screed temperature control
- MAGMALIFE Aluminium heating plates
- MAGMALIFE Automatic screed heating
- Mechanical screed lock
- Crown adjustment
- Side control of auger/scraper belts

Other

- Tools
- 8 work lights
- Three phase Generator
- Socket 240 volt

Optional Equipment

Operator compartment

- Weather protection for platform
- Seat warmer
- Asphalt steam extraction

Tractor

- Central lubrication system
- Optional paint finish
- Biologically degradable hydraulic oil
- 4 x 6 / 6 x 6 all-wheel drive
- Hydraulic hopper front flap
- Spring dampened push rollers
- Cleaning kit

Screed

- Hydraulic crown adjustment
- Heated side plates
- S 340-2 extensions:
 - 300 mm
 - 500 mm
- Reduction shoes

Levelling systems

- Height and cross-slope sensing by means of ultrasonic or mechanical sensors

Other

- Fleetmanagement BOMAG TELEMATIC
- Moon-light balloon
- Additional LED working lights

